

Annunciator Relay



MR 11 and MRE 11
MR 21 and MRE 21



The products described in this brochure are intended for industrial use and meet the requirements laid down by the EU directive 73/23/EU (issued by the Council for Coordination of the Regulations of EU Member Countries regarding the electrical equipment for use within certain voltage limits, revised by directive 93/68/EU issued by the Council)

The contents may be subject to modification for the purpose of technical improvement.
The general regulations applicable to installation and commissioning must be observed.
No warranty can be accepted.

Contents	Page
Annunciator Relay MR 11	4
Application	4
Design	4
Principle of Operation	4
Characteristics	4
Installation	4
Relay Assemblies	4
Ground-fault Annunciator Relay MRE 11	4
Application	4
Principle of Operation	4
Installation	4
Annunciator Relay MR 21	5
Application	5
Principle of Operation	5
Installation	5
Ground-fault Annunciator Relay MRE 21	5
Application	5
Principle of Operation	5
Installation	5
Technical Characteristics	5
Special Designs	5
Contact Diagrams MR 11	6
Contact Diagram MRE 11	7
Setting N/O or N/C operation	7
Contact Diagrams MR 21	8
Contact Diagram MRE 21	8
Dimensional Drawings of the Single Relays	9
Plug-in Surface Mounting	9
DIN Rail Mounting	9
Flush Mounting	9
Plug-in Flush Mounting	10
Changing the Indicator Flag Label	10
Dimensions of the Casings acc. to DIN 43700	11
4 Annunciator Relays	11
9 Annunciator Relays	11
Dimensional Drawings of the Relay Assemblies	12
Casing for Flush Mounting in Control Panel	12
Casing for Surface Mounting in Control Panel	13
Order References and Ordering Examples	14

Annunciator Relay MR 11

Application

The MR11 annunciator relay is used for the indication of danger and alarm situations and operational states. Its miniature size (39 x 46 mm ground surface) makes it suitable to be combined in large numbers so that the entire relay assembly can be used for alarm and status signalling in control rooms, control panels and mimic diagrams.

Design

The MR11 is a semi-automatic relay which can be switched in N/C or N/O mode. The required switch action - N/C or N/O - is set in the factory prior to delivery, according to customer order specifications. Subsequent modifications can be carried out by the manufacturer.

Apart from the coil excitation voltage, no other auxiliary voltage is required for visual signal indication. This is a valuable feature particularly in those applications where the relay has the task of monitoring voltages.

Principle of Operation

The entire indicator flag area is black when the relay is in its normal mode and ready for operation (optional: grey RAL 7037 indicator flag for relay assemblies). As soon as the relay picks up, the indicator flag becomes visible (white field with written characters). At the same time, the contacts move into their working position. Operating the reset button situated immediately below the indicator flag panel acknowledges the message. The indicator remains visible, but now an additional flag with red-white shaded lines appears. At the same time, the contacts return to their normal position. The relay's flag area automatically returns to its normal status upon elimination of the fault situation.

Apart from the operation described above, it is also possible to actuate the contacts directly from the pallet system. This type of contact configuration is particularly required in remote controlled plants.

Contact diagrams: see pages 6 and 7

Characteristics

Easily replaceable indicator flag label, position-independent, tropicalized protection class upon request.

Installation

Single relay

- Control panel surface mounting, plug-in
Accessories: connector plate, fixing screws with nuts
Dimensional drawing: see page 9
- DIN rail mounting (35 mm)
Accessories: connector plate with bracket
Dimensional drawing: see page 9
- Control panel flush mounting,
Accessories: strap retainer, mounting frame,
contact protection cover acc. to VBG4
Dimensional drawing: see page 9
- Control panel flush mounting, plug-in
Accessories: connector plate, fastening bow, mounting frame
Dimensional drawing: see page 10

Relay Assemblies

- Installation in DIN 43700 instrument casing designed for flush mounting in control panels
Size of casing: 96 x 96 mm for 4 relays
Size of casing: 144 x 144 mm for 9 relays
Dimensional drawings: see page 11
- Mounting in combi-enclosures for flush mounting in control panels with 150 annunciator relays max.
Dimensional drawing: see page 12
- Mounting of relay assemblies in enclosures for surface mounting in control panels, wall mounting or installation in control cubicles, with 9 relays or 4 relays
Dimensional drawings: see page 13
- Upon request, relay assemblies are delivered together with rail wires and connection angles of different heights, or these can be mounted in the factory prior to delivery. They bridge the connection points of identical potential. Upon request, relay assemblies with surface mounting enclosures are wired directly in the factory prior to delivery.
- Upon request, the relay connections are protected by a plastic cover in order to meet the VBG4 standard for protection against accidental contact.

Ground-fault Annunciator Relay MRE 11

Application

The MRE 11 annunciator relay is a semi-automatic relay used for the indication of earth leakage faults in three-phase networks.

Principle of Operation

The relay is equipped with two windings and must be connected to the open delta winding of a displacement transducer. The relay picks up at 30 V a.c. This has the effect of adding the second winding into the relay circuit which protects the relay against overload at a voltage increase up to 100 V a.c. The MRE 11 ground-fault annunciator relay is also available for other voltage ranges. Operation and indication method of the MRE 11 relay are the same as for the MR 11 relay described opposite.

Contact diagram: see page 7

Installation

identical to MR 11

Annunciator Relay MR 21

Application

Just like the MR 11, the MR 21 annunciator relay is used for the indication of danger and alarm situations and operational states. Its miniature size (39 x 46 mm ground surface) makes it suitable to be combined in large numbers so that the entire relay assembly can be used for alarm and status signalling in control rooms, control panels and mimic diagrams.

Principle of Operation

Unlike the MR 11 relay, the MR 21 annunciator relay is fully automatic. It has no manual reset button and no NO/NC change-over facility. Depending on the preset contact mode (N/O or N/C operation) the relay picks up either at energization or at de-energization. The contacts operate and the mechanical indicator flag is set. Upon return to normal of the fault situation the indicator flag is automatically acknowledged and the contacts return to their normal position.

Contact diagram: see page 8

Installation

identical to MR 11

Ground-fault Annunciator Relay MRE 21

Application

The MRE 21 is a fully-automatic annunciator relay for the indication of ground leakage faults in three-phase networks.

Principle of Operation

The MRE 21 is based on the same principle of operation as the MRE 11 relay. Only difference: as the MRE 21 is fully-automatic it has no manual reset button, nor is it equipped with a change-over facility for N/O or N/C operation.

Contact diagram: see page 8

Installation

identical to MR 11

Technical Characteristics

Excitation side

Type of current	Direct or alternating current
Frequency	50Hz or 60 Hz
Rated voltage (V_{rated} or U_N)	Up to 150 V d.c. or 230 V a.c.
Rated voltage with integrated resistor	Up to 220 V d.c.
Continuous overload capacity	$1.2 \times V_{rated}$
Pick-up voltage	$\geq 0.8 V_{rated}$

Rated current (I_N or I_{rated})
(current winding) Up to 6A d.c. or a.c.

Pick-up delay 12 ms to 25 ms

Power consumption at (V_{rated})

For d.c. 0.5 W to 1.5 W
with integrated protective resistor 1 W to 2.5 W

For a.c. and
closed magnetic circuit 1.4 VA to 1.8 VA
open magnetic circuit 2.8 VA to 3.6 VA

Contact side

Current at make 6 A d.c. or a.c.

Continuous current 4 A d.c. or a.c.

Current at disconnect
for 220 V d.c., $\frac{L}{R} = 40$ ms 0.2 A

for 220 V a.c., $\cos \varphi = 0.4$ 4 A

Permissible switching voltage 220 V d.c. or 230 V a.c.

Wiping time of fleeting contacts 60 ms approx.

General Characteristics

Protection class IP 40, connections IP 00
acc. to DIN 40050

Isolation group and series Group C, 250 V a.c./d.c.
voltage acc. to VDE 0110/11.72

Test voltage acc. to VDE 0435 a/9.72 2kV, 50 Hz

Permissible ambient temperature range -5 °C to +40 °C

Labelling 1 or 2 lines,
15 characters max. per line

Weight 310 g / 370 g standard design /
with connector plate

The front frames and front panels of relay assemblies are black varnish coated to have the same appearance as the relay screen. Upon request and at an additional charge, these parts are also available in RAL 7037 grey.

Special Designs

All annunciator relays of the MR series are also available in shock-proof design. In this case, their designation is MRS 11 and MRS 21. In addition to the standard contact diagrams shown in this brochure, a large number of special contact arrangements is available upon request, such as combinations of N/O - N/C and fleeting contacts.

Delivery range, availability and prices: on request

Contact Diagrams for MR 11 and MRE 11

Diagram reference		Relay status Normal	Message	Acknowledged
10-1	N/O current	 Magnetic system: no current	 Magnetic system: excited	 Magnetic system: excited
	N/C current	 Magnetic system: excited	 Magnetic system: no current	 Magnetic system: no current
10-2	N/O current	 Magnetic system: no current	 Magnetic system: excited	 Magnetic system: excited
	N/C current	 Magnetic system: excited	 Magnetic system: no current	 Magnetic system: no current
10-2a	N/o current	 Magnetic system: no current	 Magnetic system: excited	 Magnetic system: excited
	N/c current	 Magnetic system: excited	 Magnetic system: no current	 Magnetic system: no current
10-3	N/o current	 Magnetic system: no current	 Magnetic system: excited	 Magnetic system: excited
	N/c current	 Magnetic system: excited	 Magnetic system: no current	 Magnetic system: no current
Mechanical indicator flag		 Normal status: black	 Message status: white	 Acknowledged: white/red

Diagram reference

Relay status
Normal

Message

Acknowledged

10-3a N/O current

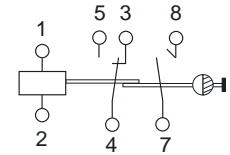
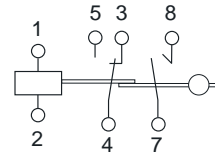
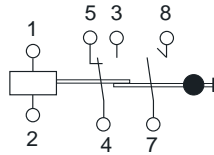

10-3a N/C current

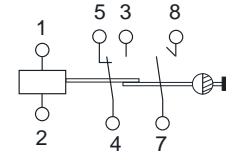
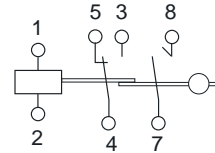
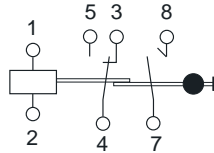

10-4 N/O current

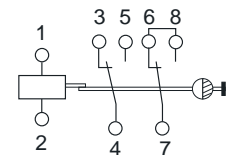
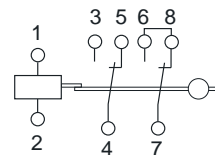
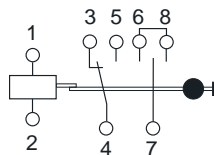

10-4 N/C current

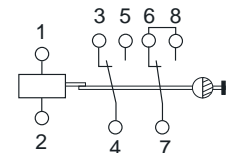
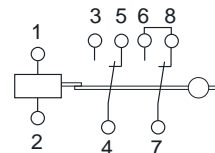
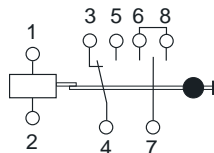

Contact Diagram MRE 11

10-1a N/O current

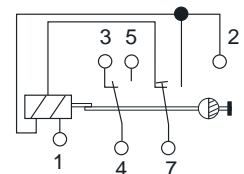
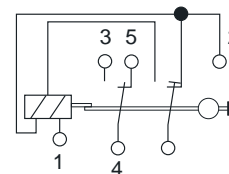
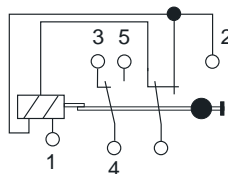

Mechanical indicator flag



Normal status: black



Message status: white



Acknowledged: whit

Setting N/O current or N/C Operation

The operation mode of the relay - N/O or N/C operation - is set in the factory according to customer order specifications. This setting can be modified.

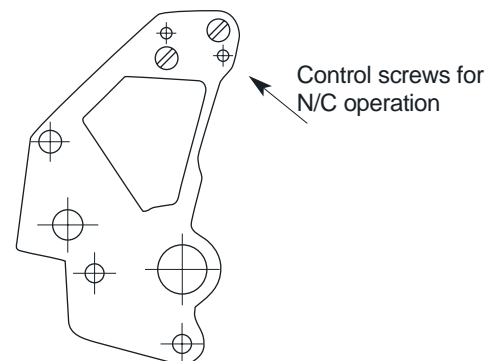
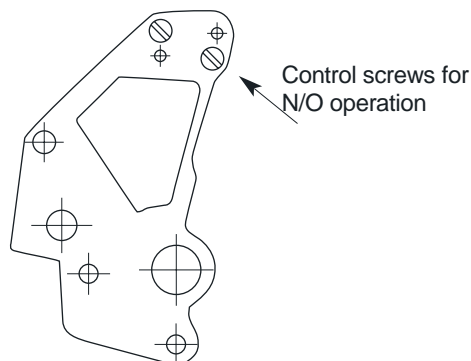

Contact Diagrams for MR 21 and MRE 21

Diagram reference		Relay status Normal	Message
20-1	N/O current		
20-1	N/C current		
20-2	N/O current		
20-2	N/C current		
20-3	N/O current		
20-3	N/C current		

Contact Diagram MRE 21

20-1a	N/C current		
-------	-------------	--	--

Mechanical indicator flag

Normal status: black
 Message status: white

Setting the N/C or N/O Operating Mode

The required operating mode of the relay is set in the factory prior to delivery and must therefore be stated on the order. It is not possible to modify this setting on site!

Plug-in Surface Mounting

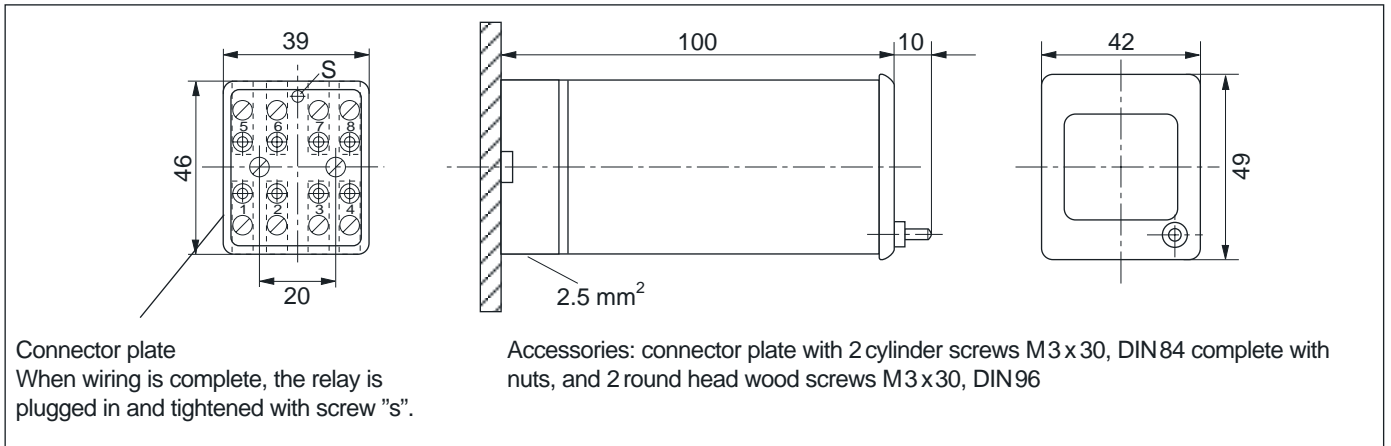

DIN Rail Mounting (35 mm)

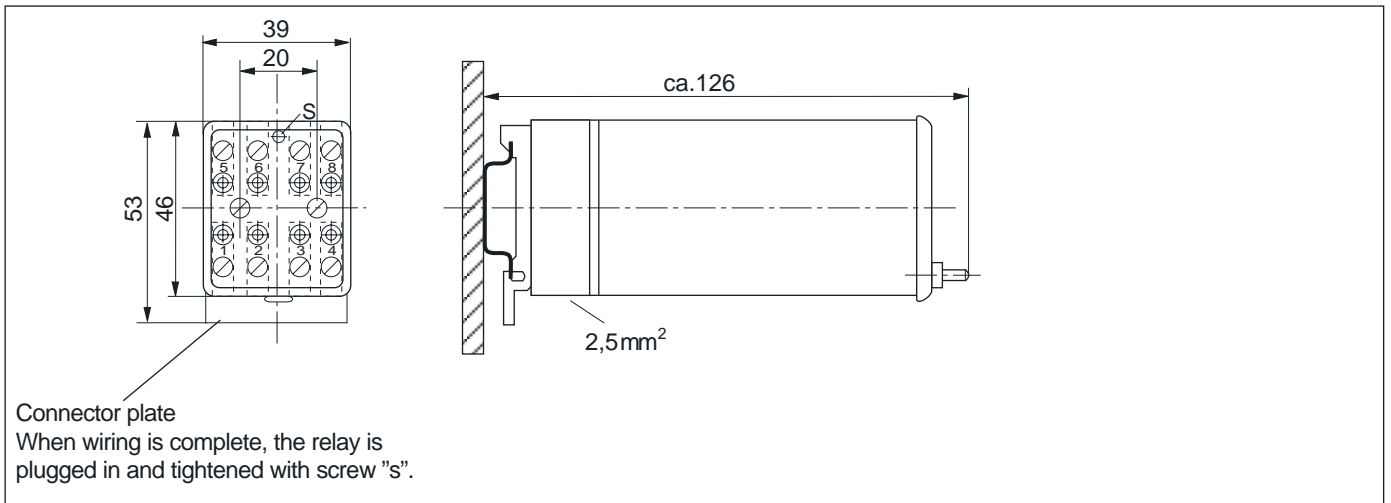

Flush Mounting

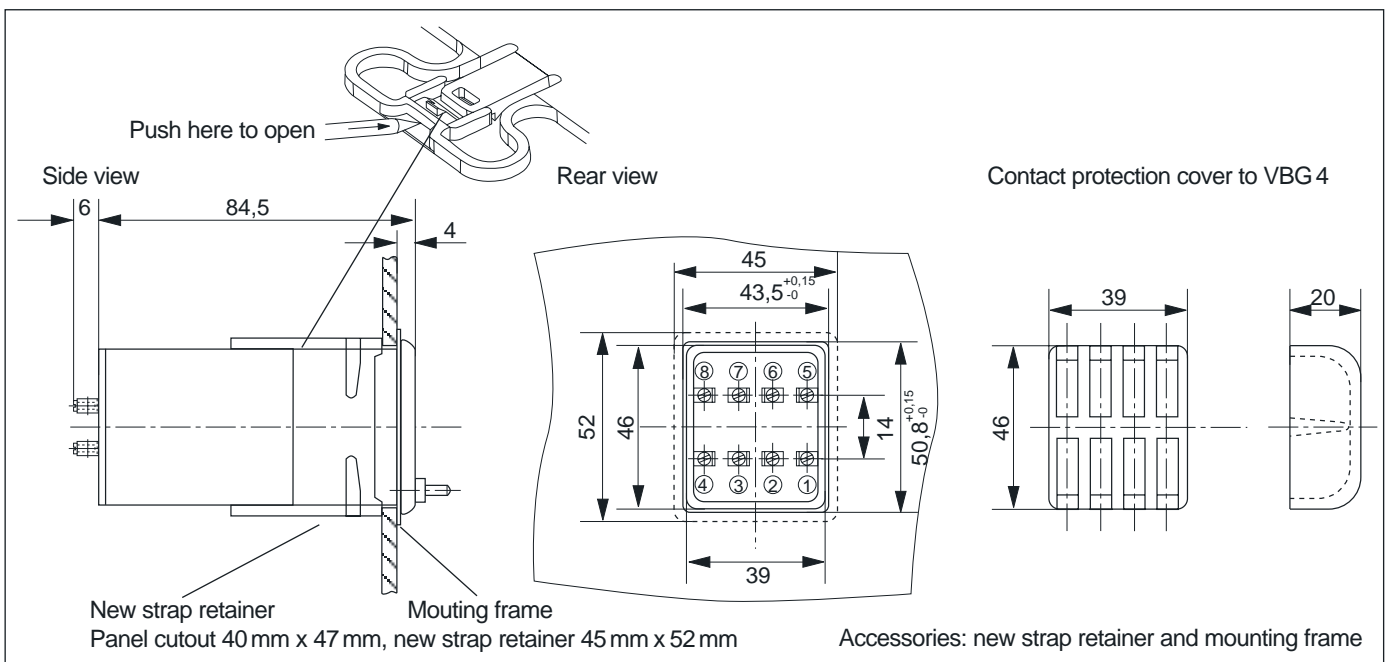

Plug-in Flush Mounting

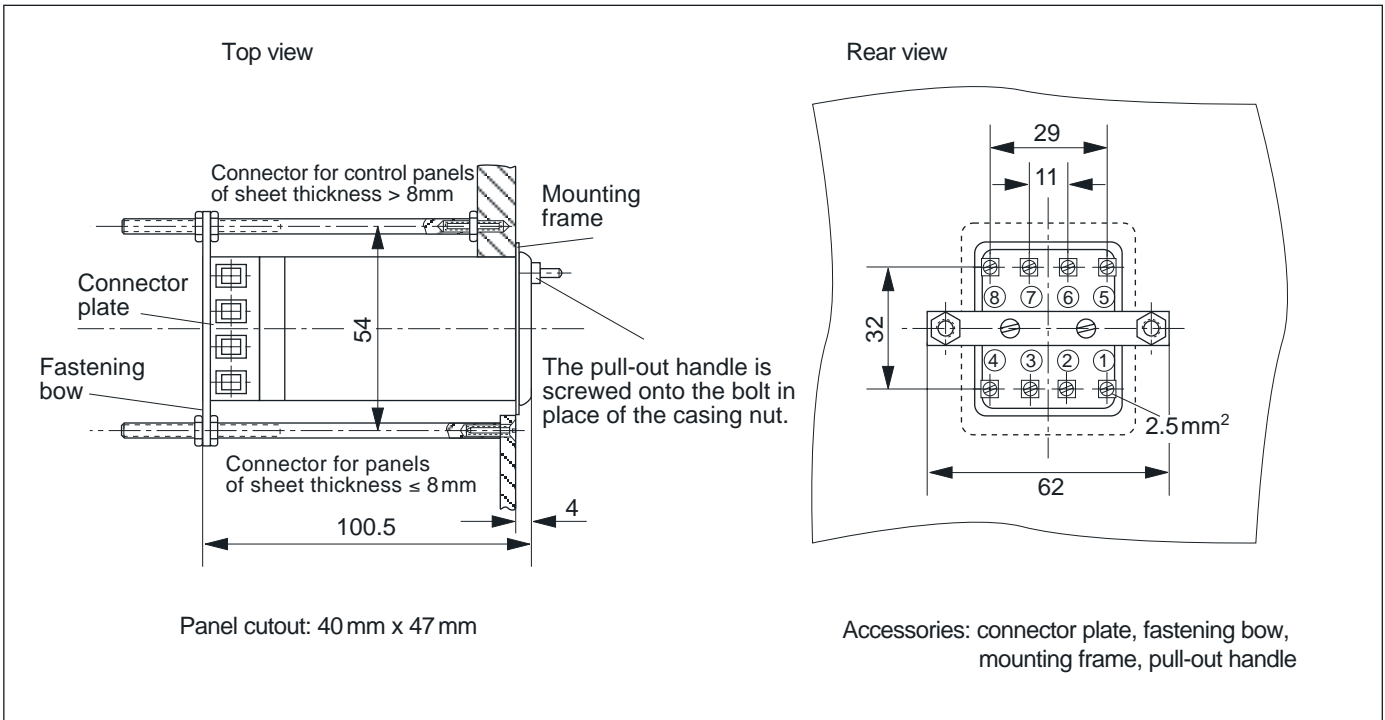

Changing the Indicator Flag Label

Removing a single relay

- Untighten the nut of the reset button situated on the front plate and pull the relay casing towards you.

Removing an annunciator relay from a combi-enclosure

- Remove the screw-type or plugged-in front frame.
- On all relays, remove the nuts of the reset buttons.
- Remove the glass cover.
- On the relay whose label you wish to change, pull the relay towards you using the pull-out handle.

Changing the label

- Flip the pallet and bend the metal sheet situated just behind the front frame until it reaches the pallet.
- Take the label out of the front frame and insert the new label.
- Please make sure that the wire strap holding the label is properly inserted in the carrier.

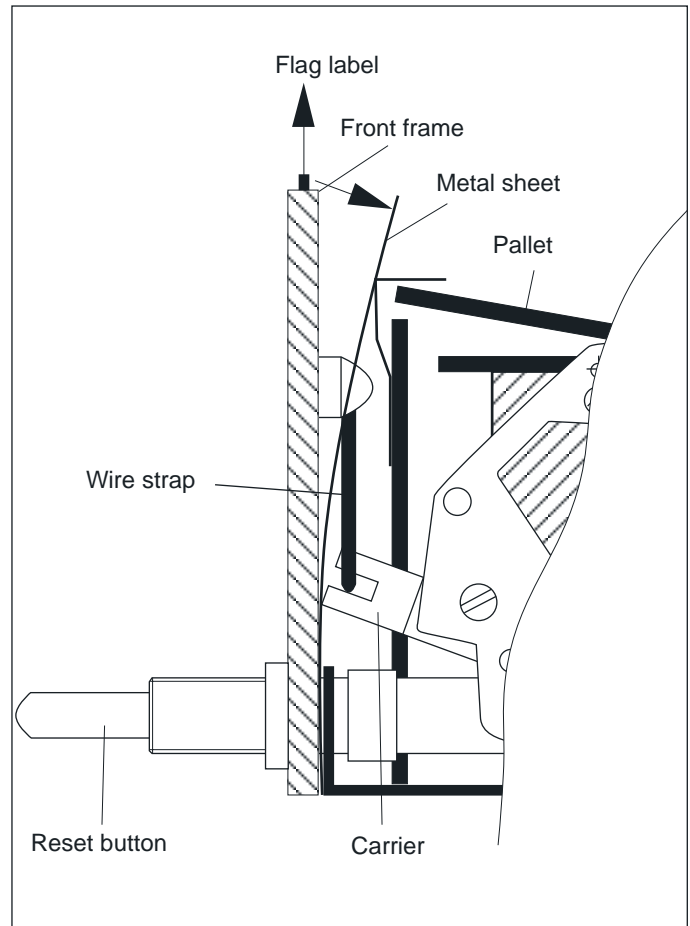

Changing the label of the mechanical indicator flag

4 annunciator relays of type MR 11 or MR 21

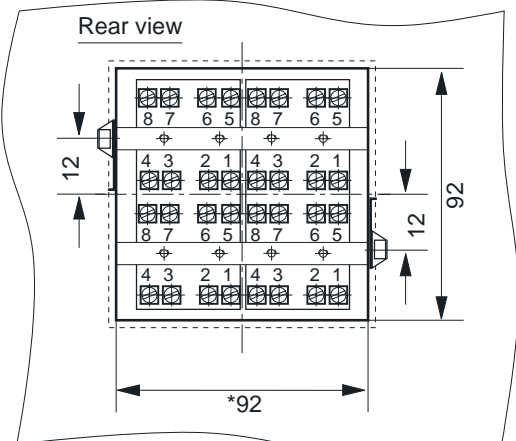
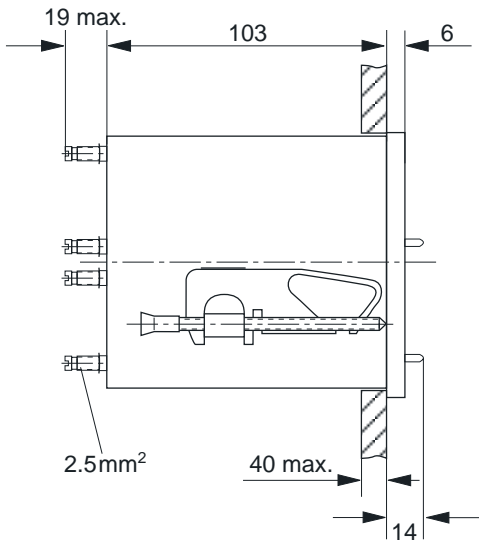
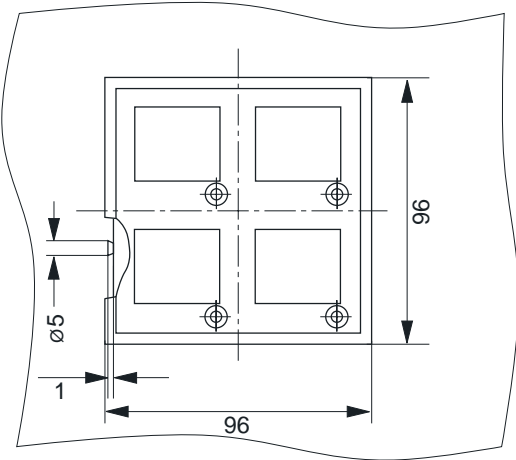

*Outer dimensions of casing, without taper rivets
Panel cutout $92^{+0,8} \times 92^{+0,8}$

9 annunciator relays of type MR 11 or MR 21

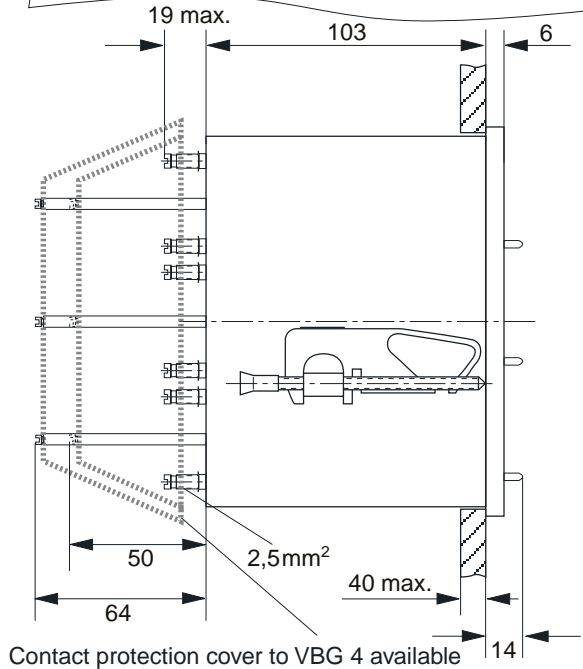
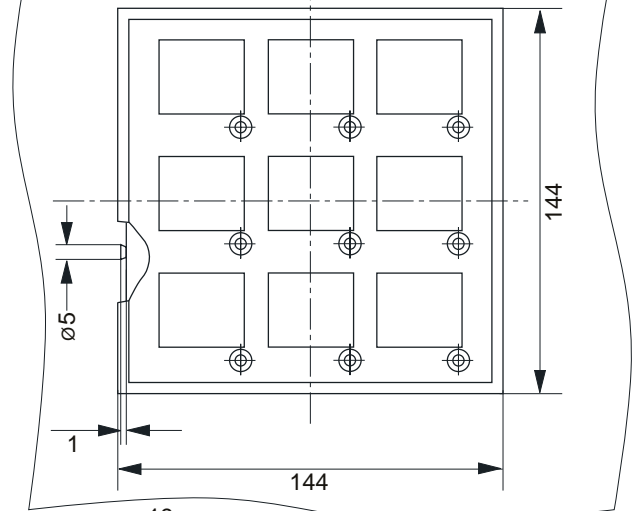

Contact protection cover to VBG 4 available

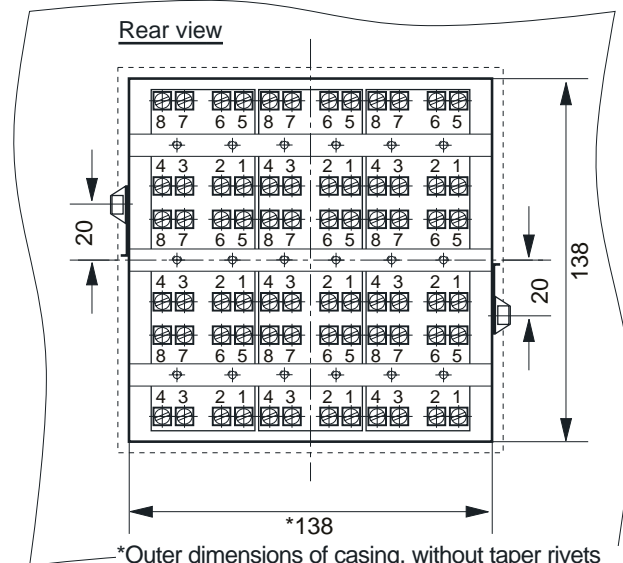

*Outer dimensions of casing, without taper rivets
Panel cutout $138^{+1} \times 138^{+1}$

Dimensions of the Relay Assemblies

Casing for Flush Mounting in Control Panel for MR 11 and MR 21

Maximum size: 150 relay slots

		70	110	150	190	230	270	310	350	390	430	470	510	550	590	630
Front frame	Panel cutout	50	90	130	170	210	250	290	330	370	410	450	490	530	570	610
		48	88	128	168	208	248	288	328	368	408	448	488	528	568	608
		1	2	3	4	5	6	7	8	9	10	11	12	13	14	15
76	56	54	1													
122	102	100	2													
168	148	146	3													
214	194	192	4													
260	240	238	5													
306	286	284	6													
352	332	330	7													
398	378	376	8													
444	424	422	9													
490	470	468	10													
536	516	514	11													
582	562	560	12													
628	608	606	13													
674	654	652	14													
720	700	698	15													

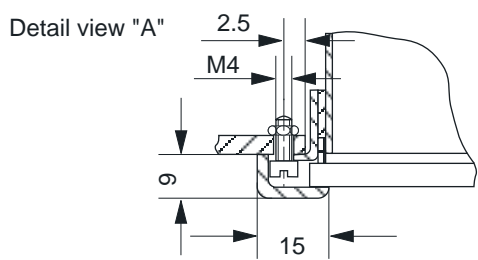
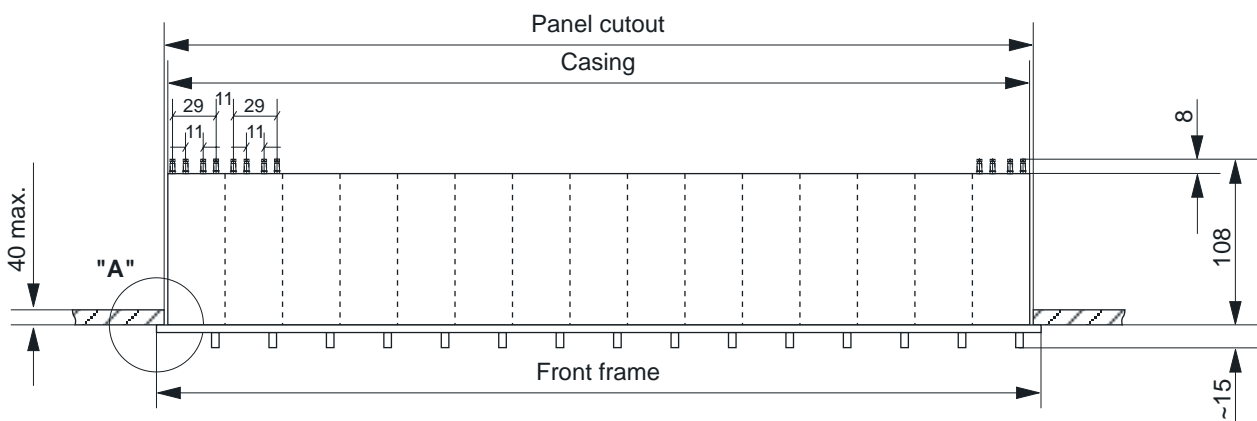

Casing for surface mounting for 4 annunciator relays

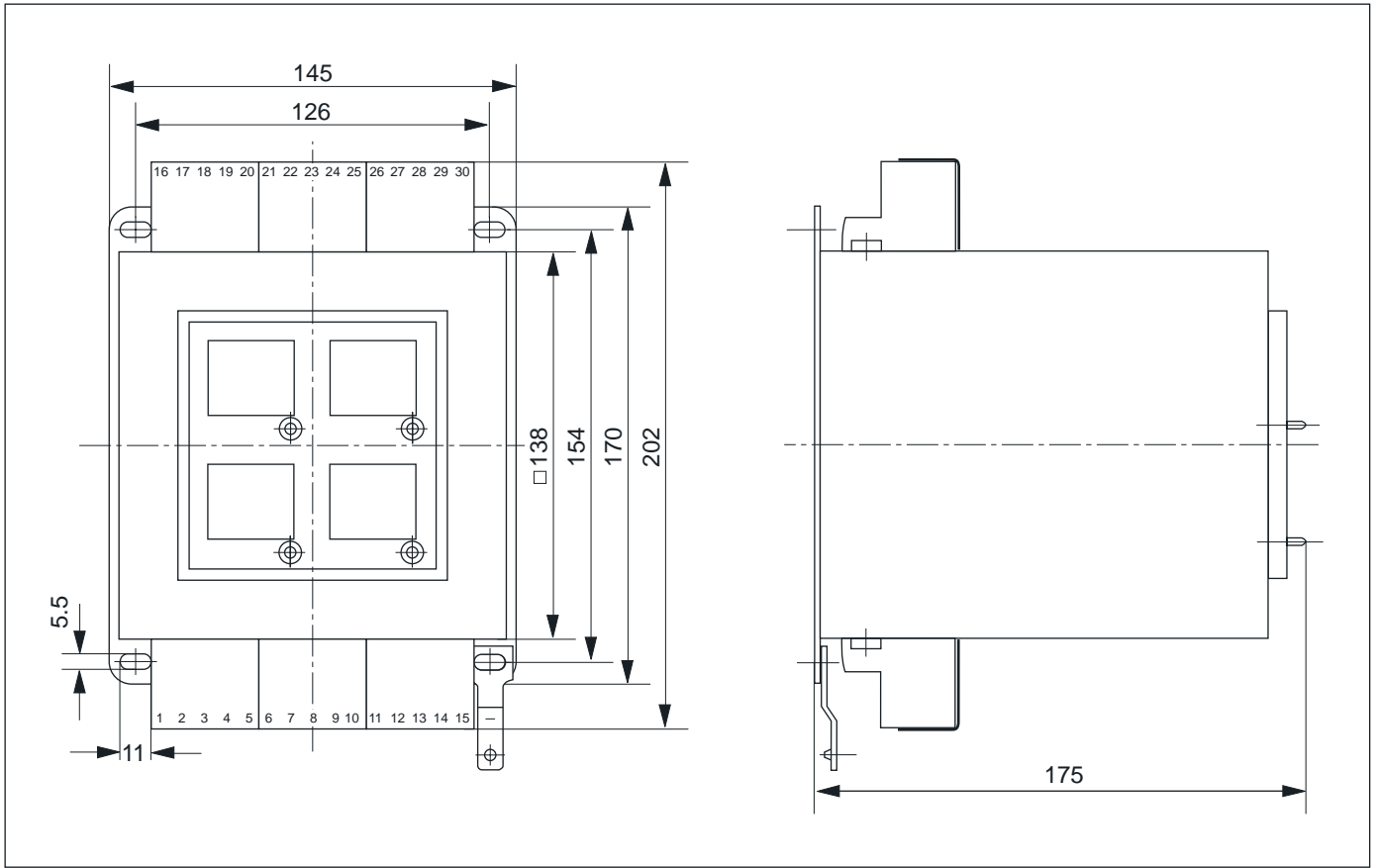

Casing for surface mounting for 9 annunciator relays

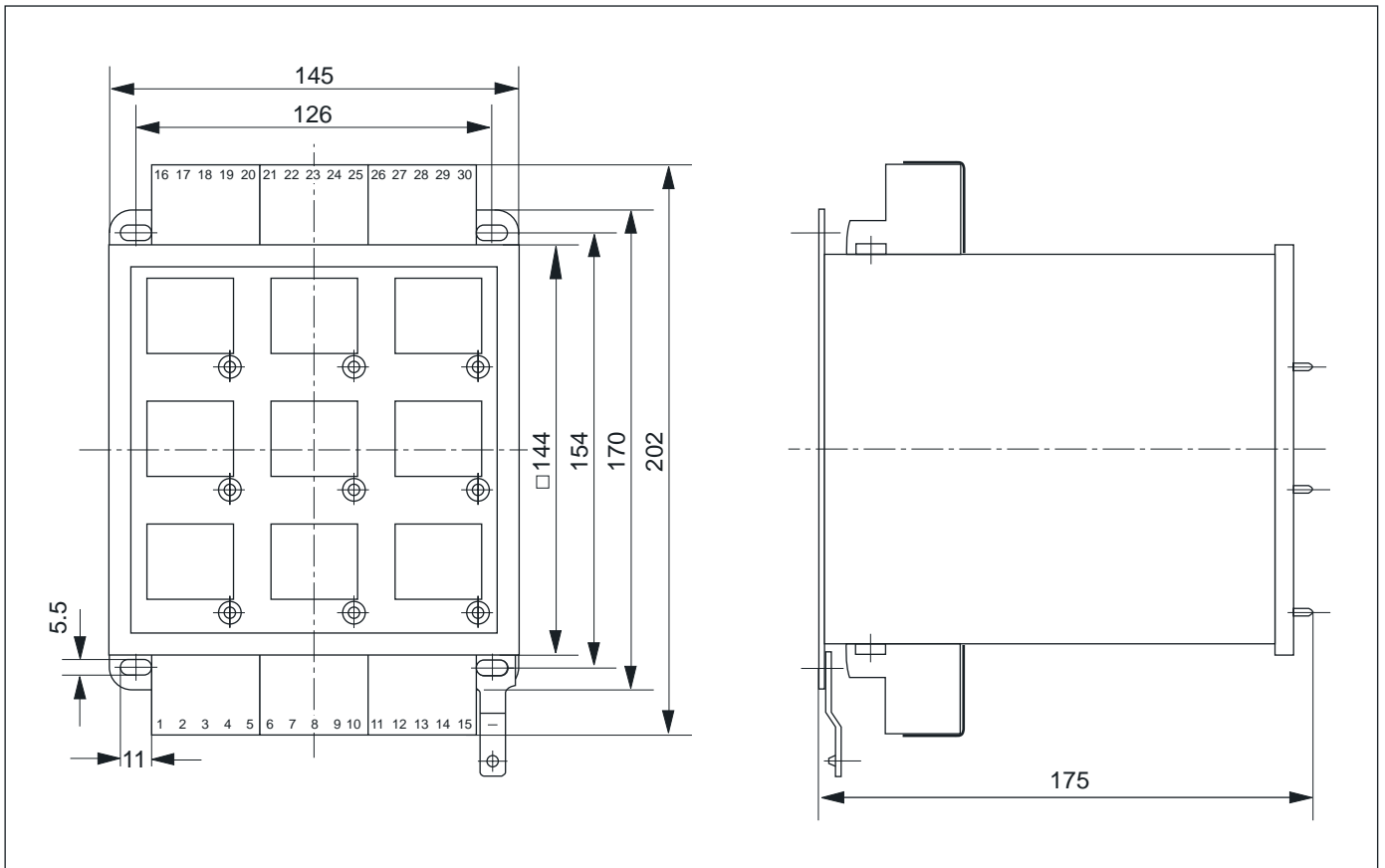

Order References and Ordering Examples

Order references, ordering examples and relay assemblies please look at our pricelist.

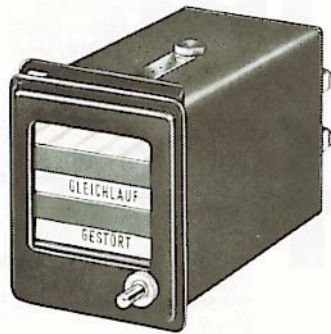

Annunciator relay MR 11
for flush mounting

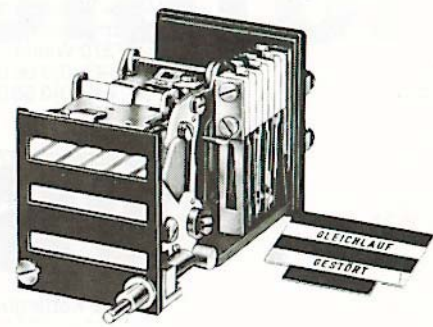

Annunciator relay MR 11
with removed label

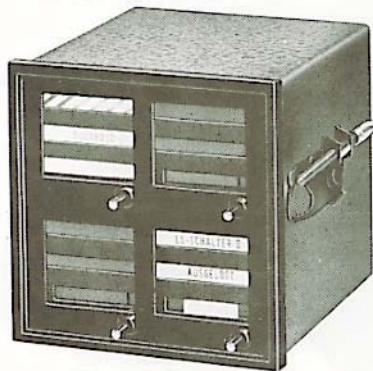

Annunciator relay assembly
96 mm x 96 mm with 4 relays

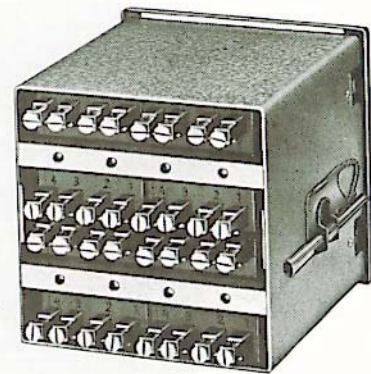

Annunciator relay assembly
96 mm x 96 mm, rear view

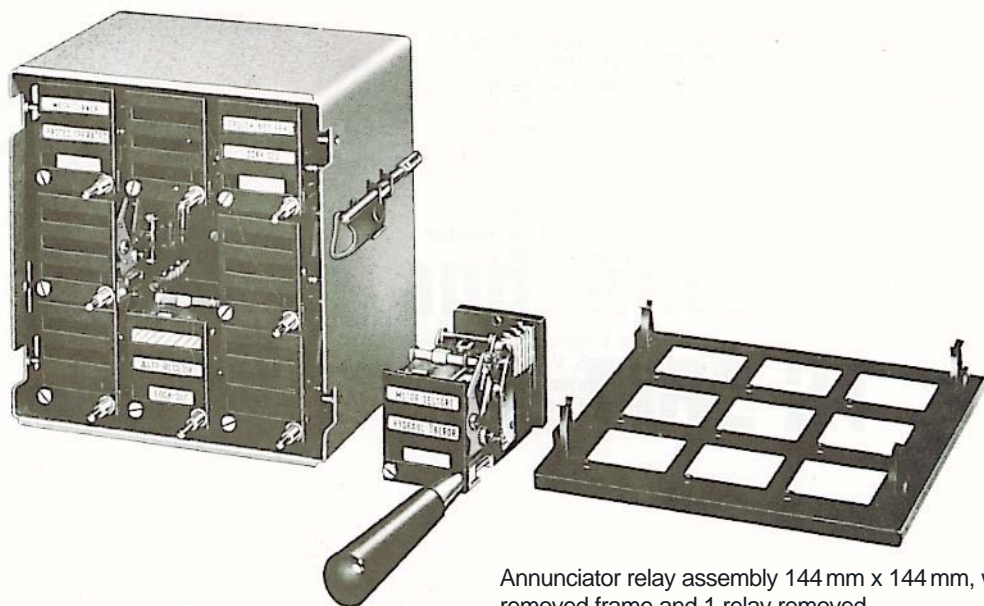

Annunciator relay assembly 144 mm x 144 mm, with
removed frame and 1 relay removed
using the pull-out handle

Representatives



Power station control and process control

Power distribution control, station control and remote control

Automation and communication systems

Industrial automation and building systems automation

Alarm indication, event recording and annunciator systems

Mosaic systems, control room technology and large-screen projection

Engineering, installation, commissioning, maintenance and training



Helmut Mauell GmbH
Am Rosenhügel 1-7
D-42553 Velbert
Deutschland
Tel. + 49 (0)20 53 1 30
Fax + 49 (0)20 53 1 34 03



Werk Weida
Papiermühlenweg 10
D-07570 Weida
Deutschland
Tel. + 49 (0)3 66 03 4 80
Fax + 49 (0)3 66 03 4 83 10



Helmut Mauell B.V.
Postbus 89
NL-3840 AB Harderwijk
Niederlande
Tel. + 31 (0)3 41 41 58 02
Fax + 31 (0)3 41 41 59 74
email info@mauell.nl



Mauell AG
Furtbachstraße 17
CH-8107 Buchs
Schweiz
Tel. + 41 (0)1 844 48 11
Fax + 41 (0)1 844 44 56
email hub@mauell.ch



Mauell Corporation
31 Old Cabin Hollow Road
Dillsburg PA 17019
USA
Tel. + 1717 4 32 86 86
Fax + 1717 4 32 86 88
email gms@mauell-us.com



Helmut Mauell do Brasil Ltda.
Estr. Est. Salvador de Leone, 2998
06850-000 Itapecerica
da Serra São Paulo / Brasilien
Tel. + 55 (0)11 79 47-17 77
Fax + 55 (0)11 79 47-17 74
email mauell@mauell.com.br

To obtain our latest list of branch offices and sales representatives in both Germany and abroad:

visit us at: www.mauell.com

email us at: info@mauell.com

or call us: + 49 (0) 20 53 - 13 432

CUSTOMER SERVICE CENTER

We also maintain a Customer Service Center staffed with knowledgeable personnel to answer your technical questions:

- + 49 (0) 20 53 - 13 - 4 90 • General inquiries
- + 49 (0) 20 53 - 13 - 4 91 • Power station and process control systems
- + 49 (0) 20 53 - 13 - 4 92 • Distribution, station and remote control systems
- + 49 (0) 20 53 - 13 - 4 93 • Industrial automation, monitoring and recording systems,
- + 49 (0) 20 53 - 13 - 4 94 • Mosaic systems, control room technology and large-screen projection
- + 49 (0) 20 53 - 13 - 4 95 • Standard devices and annunciator relays and systems